

**Diagram C**  
Proper wiring of the VDO Pyrometer

## Siemens VDO Limited Warranty

VDO North America warrants all merchandise against defects in factory workmanship and materials for a period of 24 months after purchase. This warranty applies to the first retail purchaser and covers only those products exposed to normal use or service. Provisions of this warranty shall not apply to a VDO product used for a purpose for which it is not designed, or which has been altered in any way that would be detrimental to the performance or life of the product, or misapplication, misuse, negligence or accident. On any part or product found to be defective after examination by VDO North America, VDO North America will only repair or replace the merchandise through the original selling dealer or on a direct basis. VDO North America assumes no responsibility for diagnosis, removal and/or installation labor, loss of vehicle use, loss of time, inconvenience or any other consequential expenses. The warranties herein are in lieu of any other expressed or implied warranties, including any implied warranty of merchantability or fitness, and any other obligation on the part of VDO North America, or selling dealer.

(NOTE: This is a "Limited Warranty" as defined by the Magnuson-Moss Warranty Act of 1975.)

Siemens VDO . <http://sso-usa.siemensvdo.com/> . Phone: 1-800-265-1818

## 1 BEGIN HERE

**CAUTION:** Read these instructions thoroughly before making installation. Do not deviate from assembly or wiring instructions. Always disconnect battery ground before making any electrical connections. If in doubt, please contact your dealer or VDO Instruments at 1-800-265-1818.

### Pyrometer Installation:

1. Run wires from the Pyrometer location through the firewall to:
2. Select the location where you will mount the gauge, and mark a center point.
3. Cut a 2 1/16" (52 mm) diameter hole. If the gauge is too snug, use a file to slightly

[text continues at #2] →

### Parts List

Item	Description	Quantity
1.	Pyrometer (2 1/16" [52 mm] diameter)	1
2.	Lamp Socket (Push in, wedge-type)	1
3.	Light Bulb (12-volt / G.E. #158 or equivalent)	1
4.	VDO Mounting Bracket and nuts	1
5.	Installation Instructions	1

### Tools and Materials Needed For Installation:

- 16 Gauge stranded, insulated wire
- Non-insulated 1/4" spade connectors
- 2 1/16" hole saw
- Drill and drill bit set
- Half-round file
- Tape measure or ruler
- Small tools: wrench or nut driver, utility knife, pliers, etc.
- Various engine adapters

enlarge the opening.  
(Diagram A)

4. Slip the VDO Spin-Lok™ Mounting Clamp over the back of the instrument. It's direction depends on the thickness of the panel (Diagram B). Tighten the clamp until the Pyrometer can no longer be rotated by hand.

**DO NOT OVERTIGHTEN.**

### Wiring the Pyrometer:

1. Run wires from the Pyrometer location through the firewall to:
  - a) the positive (+) terminal on the battery (both after the fuse box and after the ignition or other switch).

### CAUTION!!!

The bezel diameter is only a few millimeters larger than the gauge itself. **With that in mind, measure and precisely mark the gauge location before cutting any holes!**

# Siemens® VDO

## Pyrometer

### Installation Instructions

Instruction Sheet #0 515 012 075  
Rev. 07/03

INSTRUCTIONS FOR THE INSTALLATION OF THE PYROMETER ARE CONTAINED HEREIN. USE IS RESTRICTED TO 12-VOLT NEGATIVE GROUND ELECTRICAL SYSTEMS. LIGHT BULB, IF SUPPLIED, IS 12 VOLT.

To Begin, go to #1

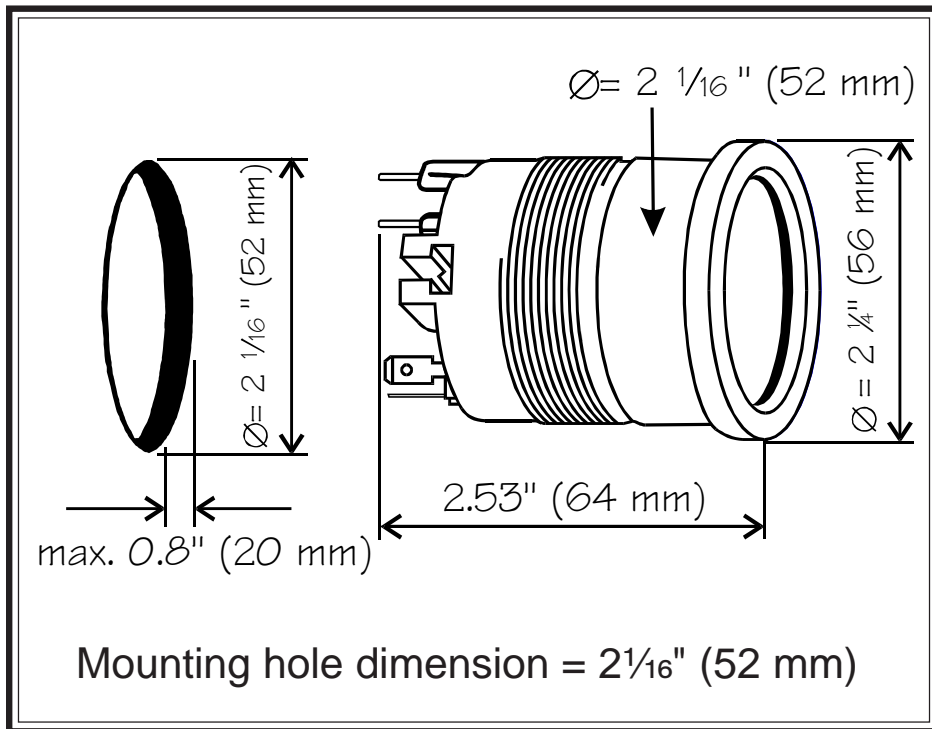

**Diagram A**  
Gauge dimensions

## 2 CONTINUE HERE

- b) the light switch (also after the fuse in the fuse box);
  - c) a good ground location (i.e., where the negative (-) battery pole is connected to the chassis of the vehicle); and
  - d) the thermocouple, which provides the signal for your pyrometer.
2. Connect the positive (+), negative [ground] (-), and the positive and negative

signal wires from the thermocouple as shown in Diagram C. Note the color-coding of the thermocouple wires.

3. Connect the appropriate positive (+) and ground (negative [-]) wires to the pyrometer lamp socket as shown in Diagram C.

At this point, the installation and wiring of your new VDO Pyrometer is complete. Turn on the ignition and the lights in the car and check to see that the instrument and light are working properly. If they aren't, re-check your wiring, referring to the wiring description in Diagram C.

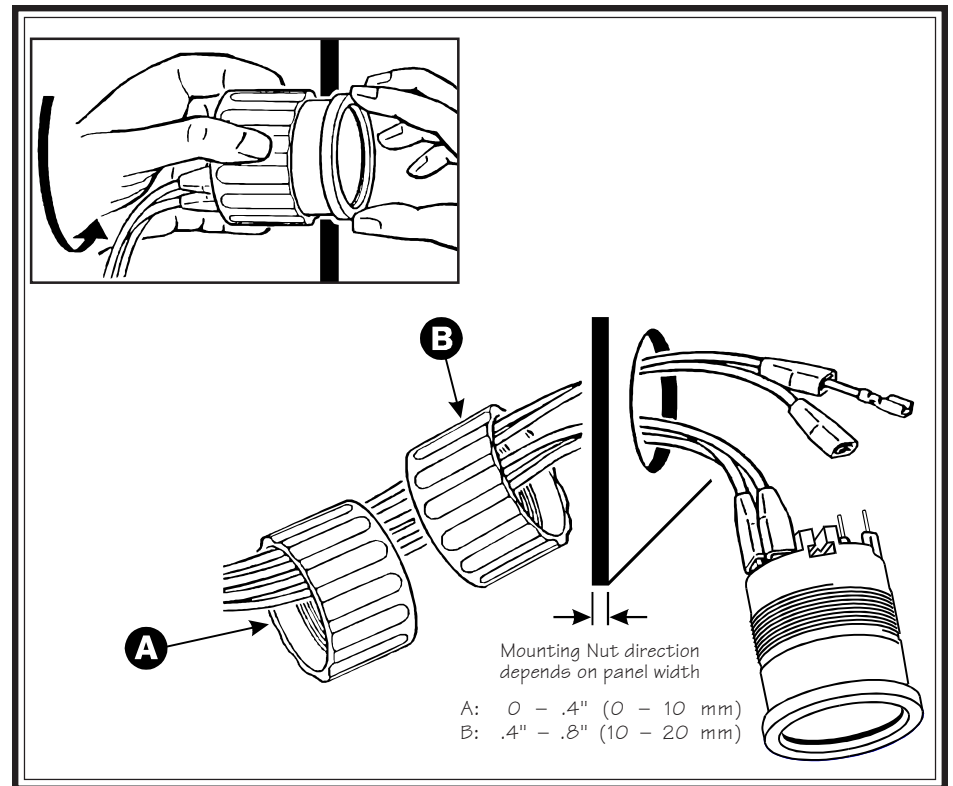

**Diagram B**  
Proper mounting using VDO's Spin-Lok™ Mounting Clamp