

# Installation Instructions

For The Fuel Level Sender Kit P/N 226 002

## VDO North America

0 515 010 176

ALLENTOWN, PA USA

THE INSTRUCTIONS FOR THE INSTALLATION OF THE BASIC FUEL SENDER KIT FOLLOW. USE IS RESTRICTED TO 12 VOLT NEGATIVE GROUND ELECTRICAL SYSTEMS.  
FOR WIRING INSTRUCTIONS, REFER TO THE FUEL GAUGE INSTRUCTIONS.

### Parts List

Item	Description	Quantity
1.	Fuel Level Sender	1
2.	Float Arm	1
3.	Gasket and Hardware Kit	1
4.	Bolt-on Installation Kit	1

### Additional Material Possibly Required To Complete Installation:

Weld-on-installation kit (optional) P/N 226 90

**CAUTION:** Read these instructions thoroughly before making installation. Do not deviate from assembly or wiring instructions. Always disconnect positive battery lead before making any electrical connections. If in doubt, please contact your dealer or VDO North America at **1-800-265-1818**

### Fuel Level Sender Installation

The Fuel Level Sender has a resistance rating of 10 ohms when the tank is empty and 180 ohms when full. Refer to the VDO North America catalog for matching fuel gauges. The unit can be adjusted to read accurately in tanks from 6" to 23" deep. For sender adjustment, refer to Table 1 and Fig. 2.

I. Measure depth of the fuel tank. Locate this dimension in Column "A" of Table 1. Column "B" then shows the length from the underside of the sender flange to the center of the float pivot. Column "C" shows the distance from the center of the float pivot to the center of the float ball. For example, a tank 12" deep would need a measurement of 6" from the flange to the pivot, and 7.8" from the pivot to the float.

II. For tank depths up to 15-1/2" it will be necessary to eliminate a part of the assembly. (See Fig. 1) Proceed as follows:

1. Remove nut "a", washer "b", and ring terminal "c" from the underside of the mounting flange.
2. Remove two screws "d" and discard.
3. Remove two screws "e" from the plastic housing and reserve for later use.
4. Carefully remove bracket "f" from the plastic housing and discard. Replace with bracket "g" in the housing and loosely re-install the two screws "e" into housing.
5. Slide housing up or down until the proper dimension from Table 1 is reached, then tighten screws securely.
6. Replace ring terminal and hardware.

**CAUTION:** Do not overtighten hardware, to avoid damage to the threads.

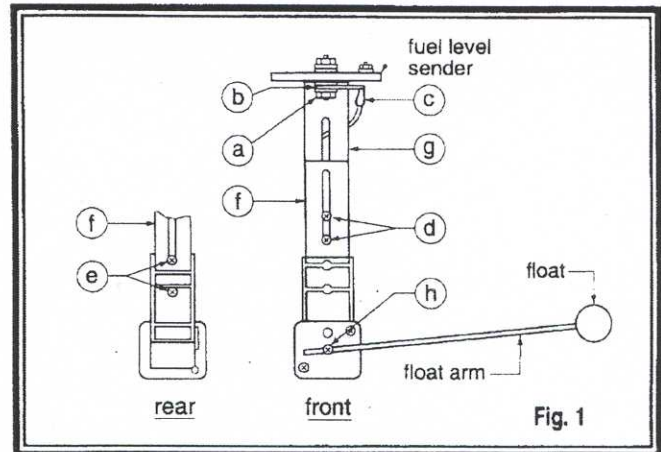

**CAUTION:** When installing the float arm into the sender body, make sure the float ball is to the right side when you face the unit, as shown in Fig. 1. If installed to the left, the fuel gauge will read "full" when the tank is empty.

III. For tank depths of 16" to 23", no disassembly of the sender bracket is necessary.

1. Remove ring terminal as instructed in Section II, above.
2. Loosen two screws "d" and adjust the plastic housing up or down until the proper dimension from Table 1 is obtained, then retighten screws securely.
3. Re-install ring terminal and hardware, and tighten all hardware securely, avoiding overtightening.

IV. To install the float assembly, loosen screw "h", remove the short piece of rod, and discard. Insert the float rod until the proper length "c" from Table 1 is met, then tighten the screw securely. Carefully cut off any excess rod with a bolt cutter or similar tool, taking care not to damage the assembly.

**NOTE:** Make sure the float is installed as shown in Fig. 1. If installed backwards, the fuel gauge will indicate "full" when the tank is empty, and "empty" when the tank is full.

VDO North America recommends that the fuel sender and the fuel gauge be wired together and checked for compatibility prior to installing fuel sender into tank.

**SAFETY PRECAUTION:** When making modifications to fuel tanks, it is essential that the tank be removed from the vehicle, and that it is empty, clean, and dry. After drilling, make sure all chips and other foreign matter have been removed from the tank.

V. Refer to Figs. 3 and 4 for installation of the fuel sender assembly into the tank. The sender flange is designed to fit a standard SAE hole pattern.

**CAUTION:** Before drilling any holes into tank, place the sender assembly on top of the tank to judge proper hole placement allowing float arm clearance inside of tank.

If no holes exist in the fuel tank (see CAUTION above):

1. Cut a 2.322" (59mm) hole in the top of the tank.
2. Pick up fuel sender and slide the rubber gasket up to the bottom of the fuel sender flange. Next, slide the second flange over fuel sender to bottom of rubber gasket. Align the pre-drilled holes in mounting flange and rubber gasket with those in fuel sender flange. Use 1" screw to connect top flange, gasket, and mounting flange. Tighten until there is .708" (18mm) between flanges. DO NOT TIGHTEN DOWN COMPLETELY.

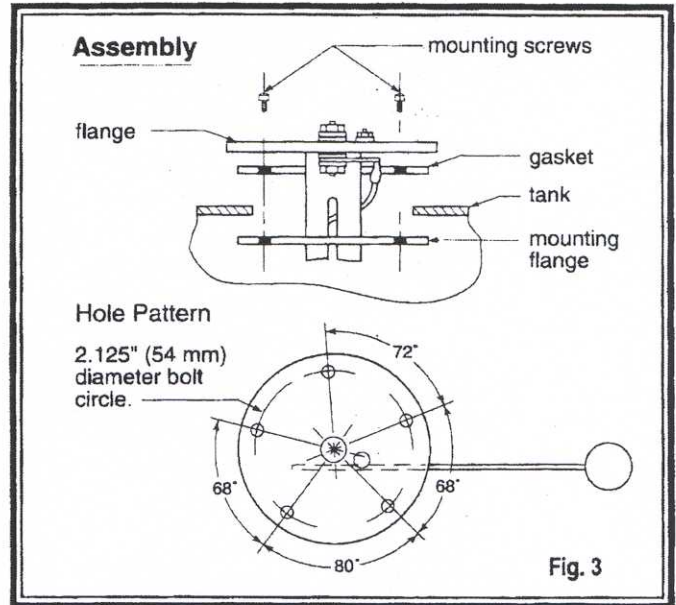

Fig. 3

3. Slip the fuel sender assembly into the 2.322" (59mm) hole in the tank, turning assembly until it goes into the tank.

**CAUTION:** Make certain float arm has a clear field of motion before tightening screws in flange assembly.

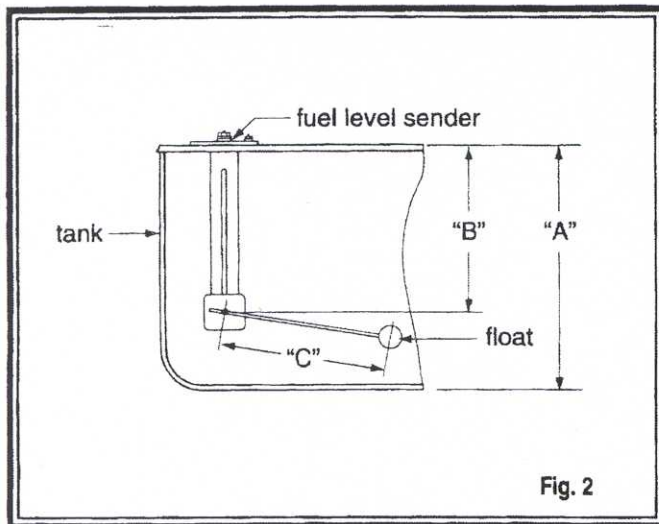

Fig. 2

**TABLE I** (dimensions in inches)

A	B	C	A	B	C	A	B	C
6.0	3.0	3.5	12.0	6.0	7.8	18.0	9.0	12.0
6.5	3.25	3.8	12.5	6.25	8.1	18.5	9.25	12.3
7.0	3.5	4.2	13.0	6.5	8.5	19.0	9.5	12.6
7.5	3.75	4.5	13.5	6.75	8.9	19.5	9.75	12.9
8.0	4.0	4.9	14.0	7.0	9.3	20.0	10.0	13.4
8.5	4.25	5.3	14.5	7.25	9.6	20.5	10.25	13.8
9.0	4.5	5.6	15.0	7.5	10.0	21.0	10.5	14.2
9.5	4.75	6.0	15.5	7.75	10.4	21.5	10.75	14.6
10.0	5.0	6.4	16.0	8.0	10.7	22.0	11.0	15.0
10.5	5.25	6.7	16.5	8.25	11.0	22.5	11.25	15.4
11.0	5.5	7.1	17.0	8.5	11.4	23.0	11.5	15.7
11.5	5.75	7.4	17.5	8.75	11.8			

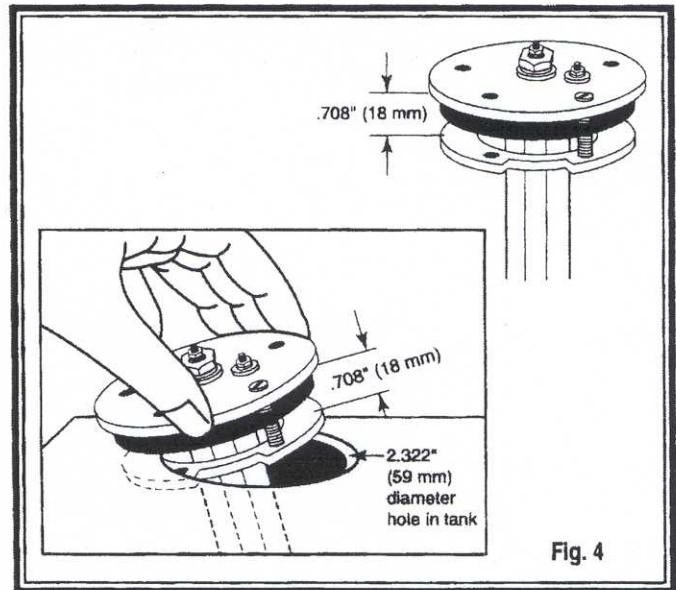

Fig. 4

## Siemens VDO Limited Warranty

VDO North America warrants all merchandise against defects in factory workmanship and materials for a period of 24 months after purchase. This warranty applies to the first retail purchaser and covers only those products exposed to normal use or service. Provisions of this warranty shall not apply to a VDO product used for a purpose for which it is not designed, or which has been altered in any way that would be detrimental to the performance or life of the product, or misapplication, misuse, negligence or accident. On any part or product found to be defective after examination by VDO North America, VDO North America will only repair or replace

the merchandise through the original selling dealer or on a direct basis. VDO North America assumes no responsibility for diagnosis, removal and/or installation labor, loss of vehicle use, loss of time, inconvenience or any other consequential expenses. The warranties herein are in lieu of any other expressed or implied warranties, including any implied warranty of merchantability or fitness, and any other obligation on the part of VDO North America, or selling dealer.

**(NOTE: This is a "Limited Warranty" as defined by the Magnuson-Moss Warranty Act of 1975.)**