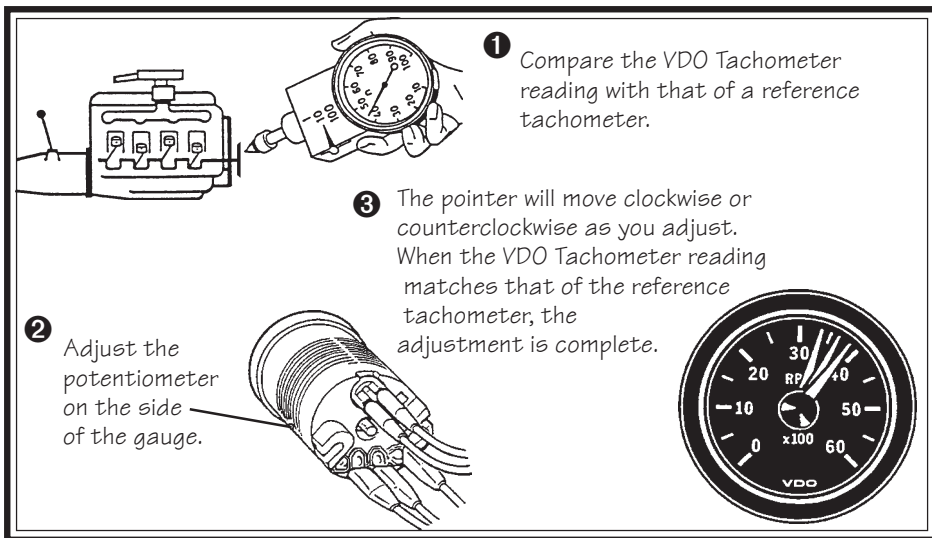

**Diagram D**

Tachometer configuration for use with ignition coil (top); alternator (bottom)



**Diagram E**

Fine tachometer adjustment needed when using a pulse-per-revolution signal

### VDO Limited Warranty

VDO North America warrants all merchandise against defects in factory workmanship and materials for a period of 24 months after purchase. This warranty applies to the first retail purchaser and covers only those products exposed to normal use or service. Provisions of this warranty shall not apply to a VDO product used for a purpose for which it is not designed, or which has been altered in any way that would be detrimental to the performance or life of the product, or misapplication, misuse, negligence or accident. On any part or product found to be defective after examination by VDO North America, VDO North America will only repair or replace the merchandise through the original selling dealer or on a direct basis. VDO North America assumes no responsibility for diagnosis, removal and/or installation labor, loss of vehicle use, loss of time, inconvenience or any other consequential expenses. The warranties herein are in lieu of any other expressed or implied warranties, including any implied warranty of merchantability or fitness, and any other obligation on the part of VDO North America, or selling dealer.

(NOTE: This is a "Limited Warranty" as defined by the Magnuson-Moss Warranty Act of 1975.)

VDO North America · 188 Brooke Rd. · P.O. Box 2897 · Winchester, VA 22603 · Phone: 540-665-2428

## 1 BEGIN HERE

**CAUTION:** Read these instructions thoroughly before making installation. Do not deviate from assembly or wiring instructions. Always disconnect battery ground before making any electrical connections. If in doubt, please contact your dealer or VDO Instruments at (540) 665-2428.

### Tachometer Installation:

1. Select the location where you will mount the gauge, and cut a 2 1/16" hole as shown in Diagram A.
2. Slip the VDO Spin-Lok™ Mounting

### CAUTION!!!

The bezel diameter is only a few millimeters larger than the gauge itself. **With that in mind, measure and precisely mark the gauge location before cutting any holes!**

### Tools and Materials Needed For Installation:

- 16 Gauge stranded, insulated wire
- Non-insulated 1/4" spade connectors
- 2 1/16" hole saw
- Drill and drill bit set
- Half-round file
- Tape measure or ruler
- Small tools: wrench or nut driver, utility knife, pliers, etc.

Clamp over the back of the instrument. Its direction depends on the thickness of the panel (Diagram B). Tighten the clamp until the gauge can no longer be rotated by hand.

**DO NOT OVERTIGHTEN.**

### Tachometer Wiring:

1. Run wires from the tachometer location to:
  - a) A +12 volt power terminal. (This positive power source **MUST BE SWITCHED**, and should be protected with a fuse);
  - b) the light switch (also after the fuse in the fuse box);
  - c) a good ground location;

[text continues at #2] ➔

### Parts List

Item	Description	Quantity
1.	Tachometer (2 1/16" [52 mm] diameter)	1
2.	Lamp Socket (Push in, wedge-type)	1
3.	Light Bulb (12-volt / G.E. #158 or equivalent)	1
4.	VDO Spin-Lok™ Clamp	1
5.	Installation Instructions	1

**VDO® North America**

### Tachometer Installation Instructions

Instruction Sheet #0 515 012 044  
Rev.03/00

INSTRUCTIONS FOR THE INSTALLATION OF THE TACHOMETER ARE CONTAINED HEREIN. USE IS RESTRICTED TO 12-VOLT NEGATIVE GROUND ELECTRICAL SYSTEMS. LIGHT BULB, IF SUPPLIED, IS 12 VOLT.

To Begin, go to #1

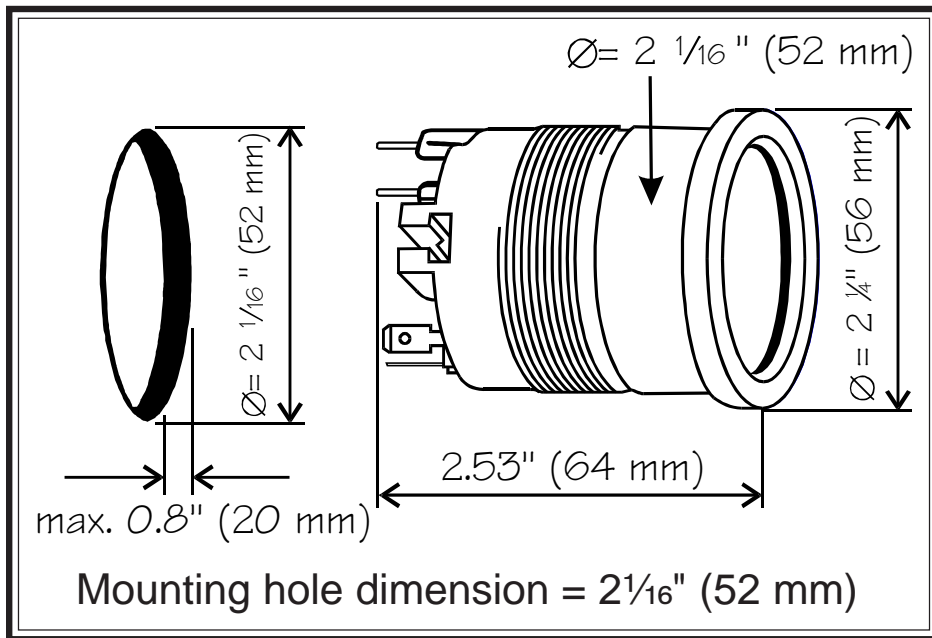

**Diagram A**  
Gauge dimensions

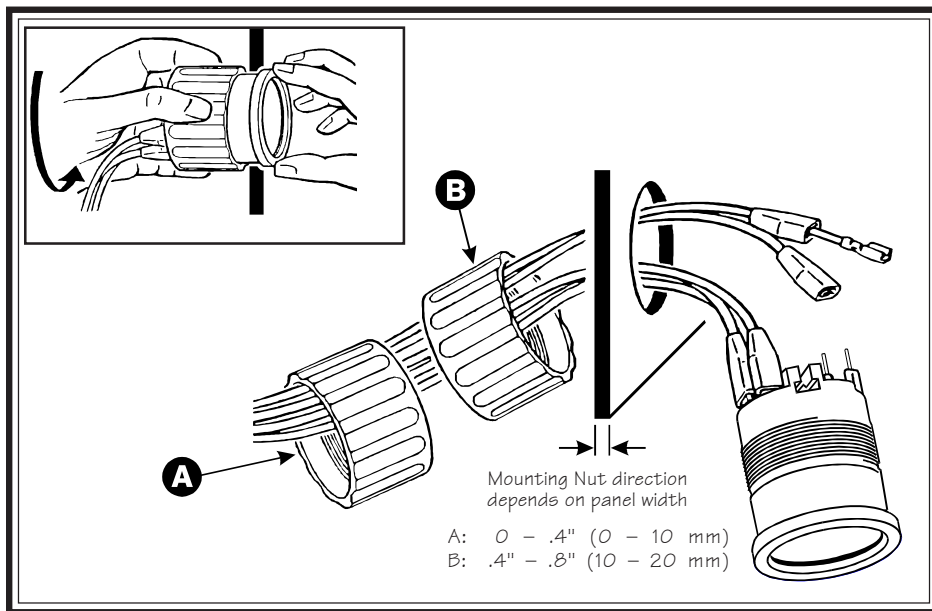

**Diagram B**  
Proper mounting using VDO's Spin-Lok™ Mounting Clamp

## 2 CONTINUE HERE

d) the location of the signal source (alternator, coil or other ignition signal source).

2. Connect the wiring to the appropriate tachometer terminals as shown in Diagram C.

### Configuring the Tachometer:

Before your VDO Tachometer will function properly with your engine, you will need to configure it as shown in Diagram D.

The table at the top of Diagram D shows how to set the DIP switches for use with an ignition coil; the table at the bottom shows how to set the DIP switches when using the tachometer with an alternator.

When using the VDO Tachometer with

another type of ignition system, determine the number of pulses per revolution the ignition signal provides, and set the DIP switches as shown in the bottom table.

### Adjusting the Tachometer Pointer:

*Use of the VDO Tachometer with an alternator or other type of ignition that provides a signal in pulses per revolution may require calibration of the pointer.*

This can be done as show in Diagram E. Please note that this calibration is designed to adjust the reading between 30% and 100% of the RPM range.

At this point, the installation and wiring of your new VDO Tachometer is complete. Turn on the ignition and the lights in the car and check to see that the instrument and light work properly. If they don't, re-check your wiring, referring to the wiring description in Diagram C.

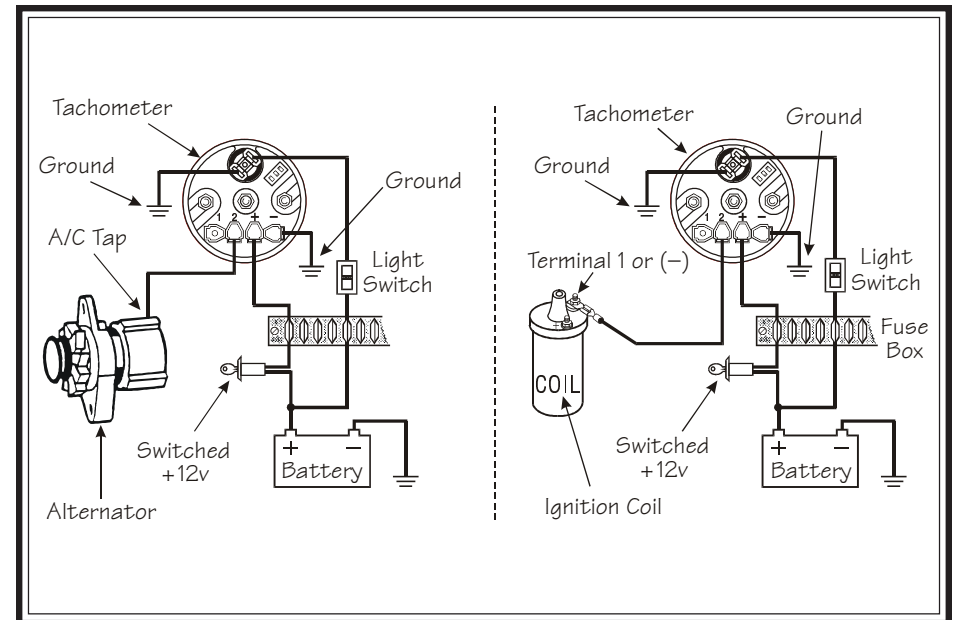

**Diagram C**  
Tachometer wiring with Alternator AC Tap (left); and with Ignition Coil (right)